



DATENBLATT | MC TR +/-

KURZBESCHREIBUNG

- Trennrelais zur Steuerung eines oder mehrerer Gleichstrom-
- Antriebe, welche durch Umschalten der Polarität in der Laufrichtung gesteuert werden
- Spritzwassergeschützte Abzweigdose
- Einbau in eine 55er UP-Dose mit tiefem Klemmraum möglich



TECHNISCHE DATEN

PARAMETER	WERT
Steuerspannung	230VAC, 50 Hz
Bemessungs-Stoßspannung	2,5 kV
Leistungsaufnahme	< 1 W
Ausgang Schaltleistung	30VDC, 5A
Betriebstemperaturbereich	0°C bis +40°C
Schutzart	IP 54
Verschmutzungsgrad	2
Maße (L x W x H)	85 x 85 x 40 mm (ohne Befestigungslaschen)
Konformität	CE

ABMESSUNGEN

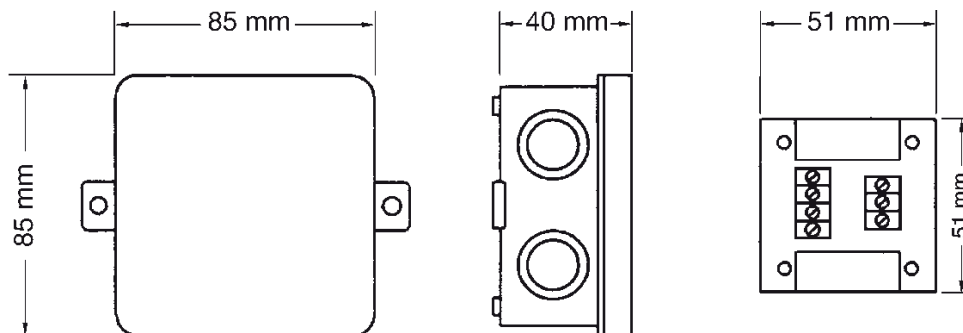



ANSCHLUSSPLAN

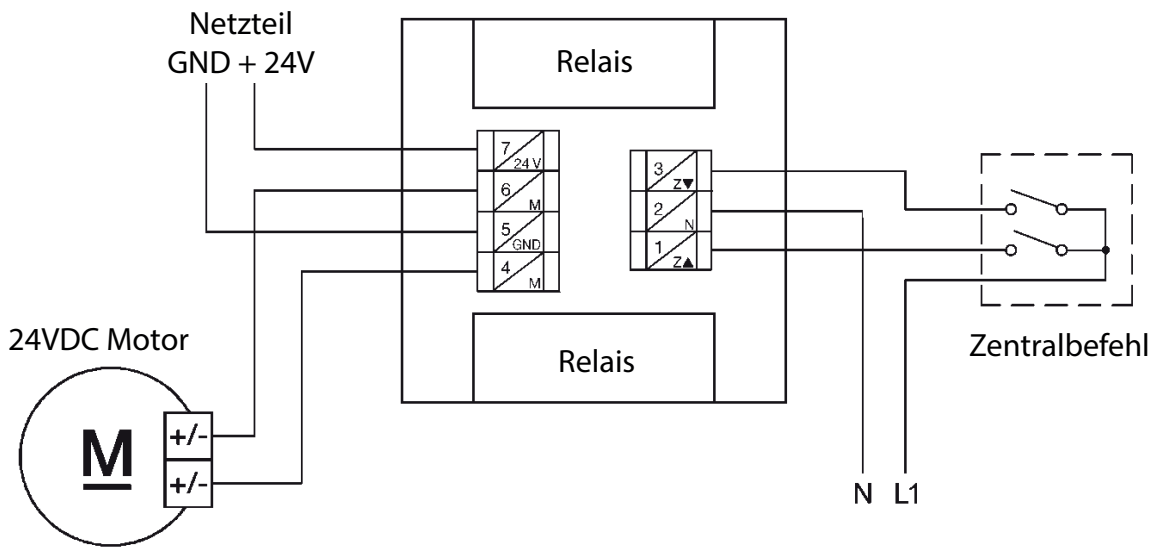

PARALLELSCHALTUNG VON MEHREREN MOTOREN

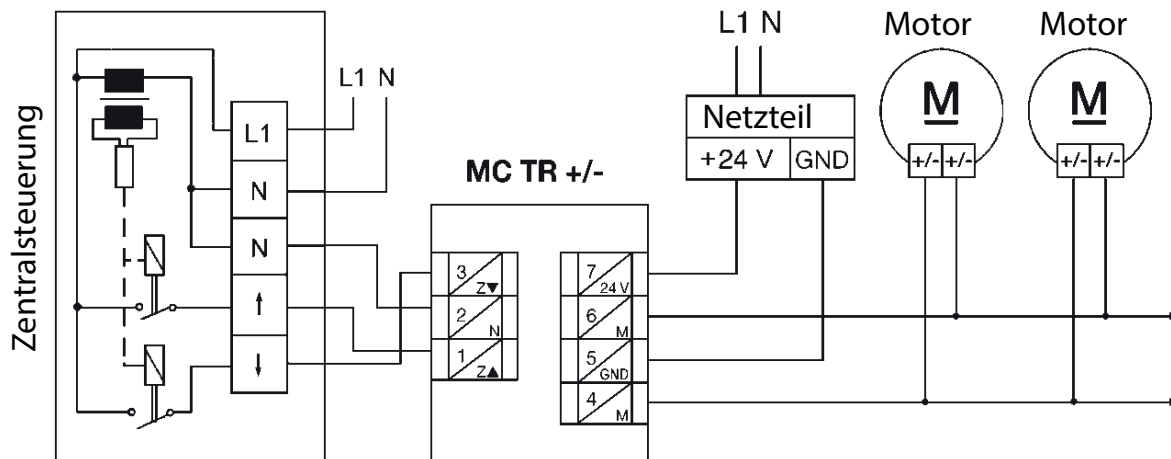

INNENSCHALTBILD

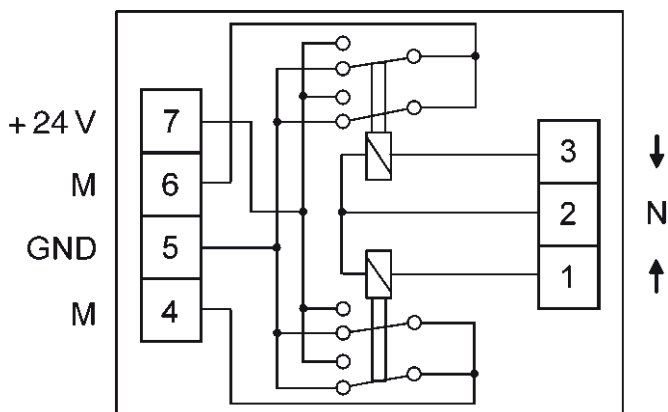



DATA SHEET | MC TR +/-

SHORT DESCRIPTION

- Relay for controlling one or more DC drives
- Drives controlled by reversing polarity in the direction of travel via a changeover switch
- Splash-proof junction box
- Installation in a 55 mm flush-mounted box with deep terminal space possible



TECHNICAL DATA

PARAMETER	VALUE
Control voltage	230VAC, 50 Hz
Impulse voltage withstand level	2,5 kV
Rated power	< 1 W
Output Maximum load:	30VDC, 5A
Operating temperature	0 °C (32 °F) to +40 °C (104 °F)
IP class	IP 54
Degree of pollution	2
Dimensions (L x W x H)	85 x 85 x 40 mm (without mounting brackets)
Conformität	CE

DIMENSIONS

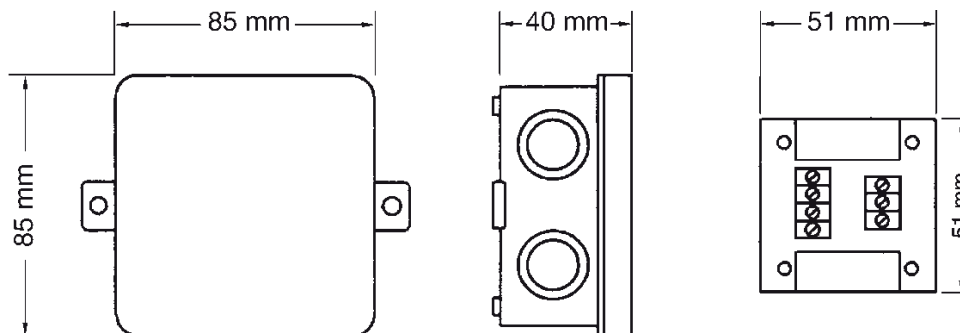



WIRING DIAGRAM

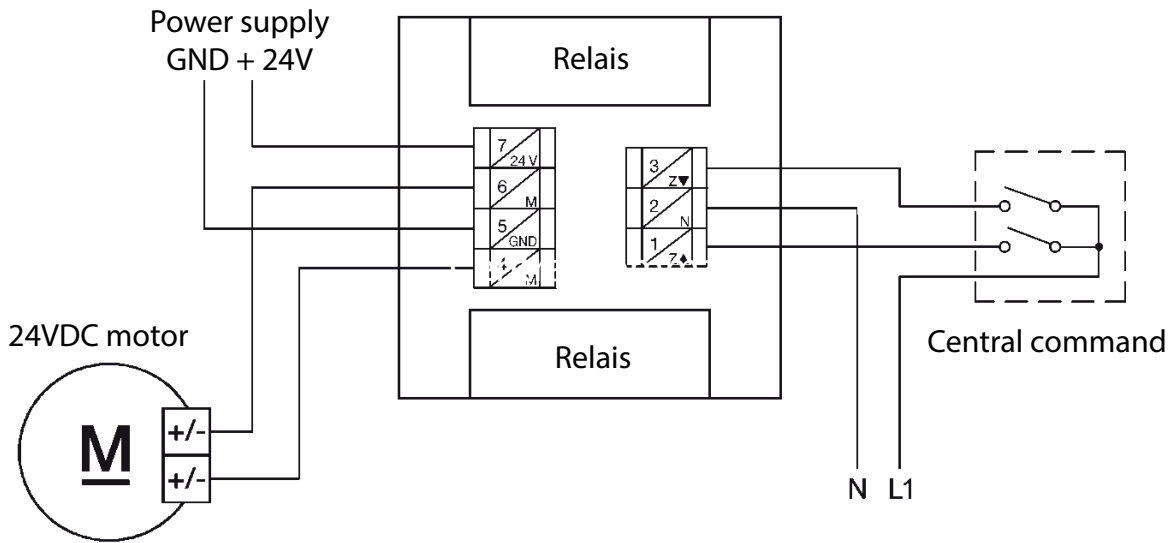

CONNECTING SEVERAL MOTORS IN PARALLEL

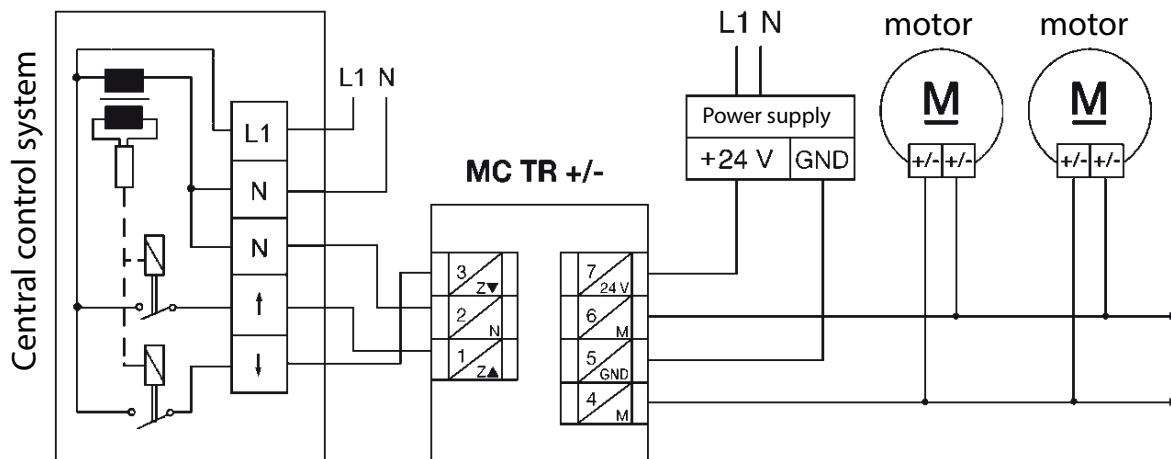

INTERNAL CIRCUIT DIAGRAM

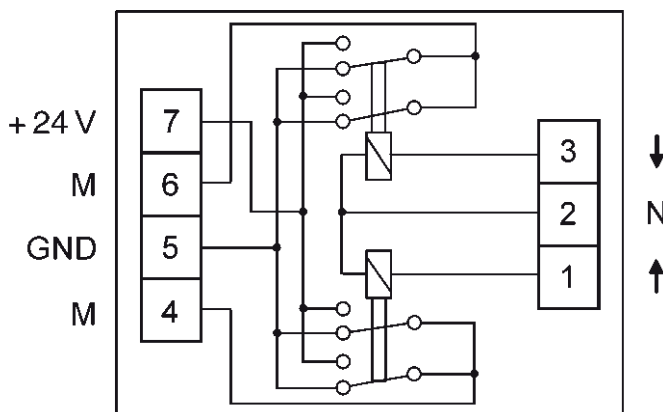





GEGEVENSBLAD | MC TR +/-

KORTE BESCHRIJVING

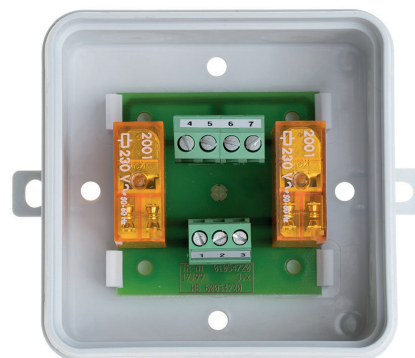
- Scheidingsrelais voor de besturing van één of meerdere gelijkstroomaandrijvingen
- Aandrijvingen waarvan de draairichting via omschakeling van de polariteit wordt gestuurd
- Spatwaterdichte aftakdoos
- Inbouw mogelijk in een 55 mm inbouwdoos met diepe aansluitruimte



TECHNISCHE GEGEVENS

PARAMETER	WAARDE
Stuurspanning	230VAC, 50 Hz
Nominale stootspanning	2,5 kV
Vermogensopname	< 1 W
Uitgang Schakelvermogen	30VDC, 5A
Bedrijfstemperatuur	0°C bis +40°C
Beschermingsgraad	IP 54
Vervuilingsgraad	2
Afmetingen (L x W x H)	85 x 85 x 40 mm (zonder bevestigingslippen)
Conformiteit	

AFMETINGEN VAN DE BEHUIZING

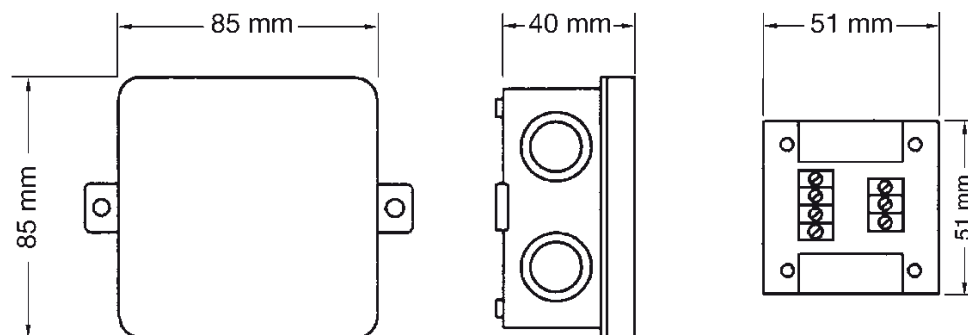



AANSLUITSCHEMA

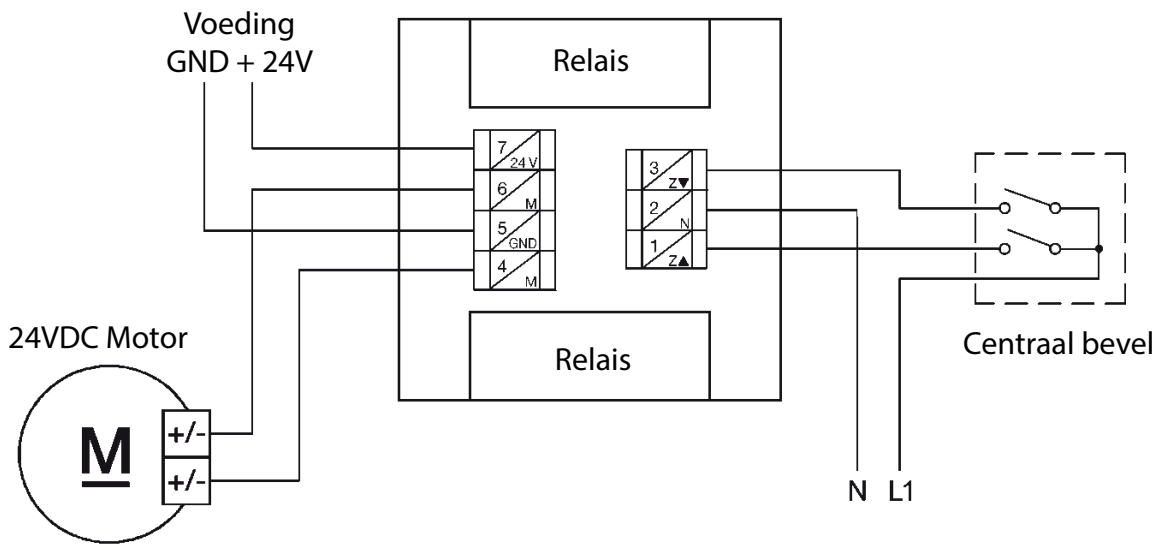

PARALLELSCHAKELING VAN MEERDERE MOTOREN

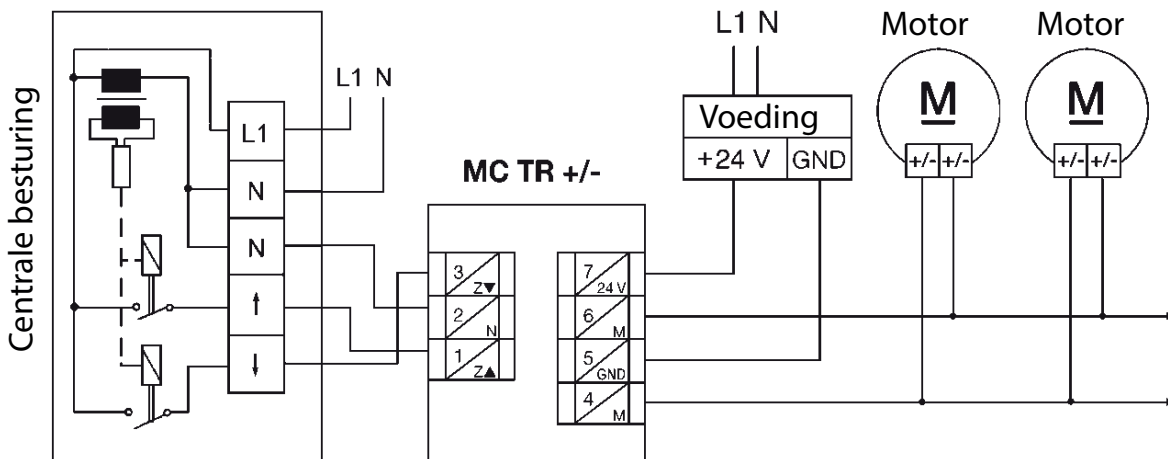

SCHEMA VAN DE INTERNE SCHAKELING

